

PRODUCT DATA SHEET

Panasonic

Product Name :	Duoble One Way Push Button Mechanism+Button
Product Code :	PN.T01132 XX
Product Series :	Karre Plus
Technical Specifications :	
Rated Current :	10AX, 250V~
Terminal Type :	Quick Connection
Material of Button :	ABS (Acrylonitrile Butadine-Styrene)
Certifications :	VDE, EAC, CE, WEEE
Colour Options XX :	WH: White, DG: Dark Grey, SL: Silver, BL: Black
Cable Standard:	
Cable Diameter :	1mm ² -2,5mm ²
Applicable Cable:	Solid Wire, Stranded Wire



Wiring and Circuit Diagram :

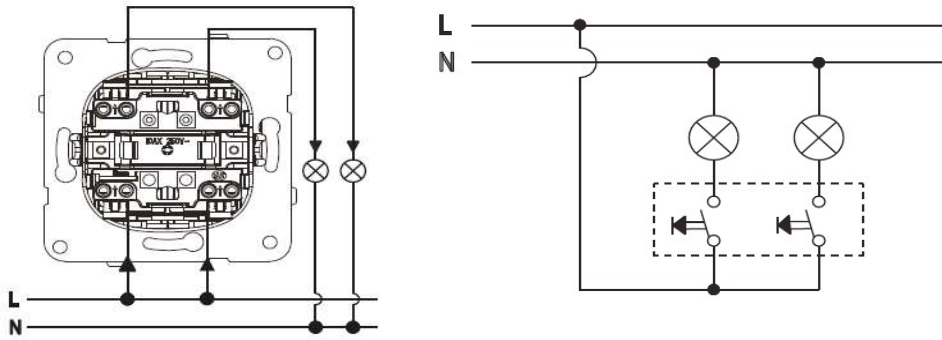

Dimensions :

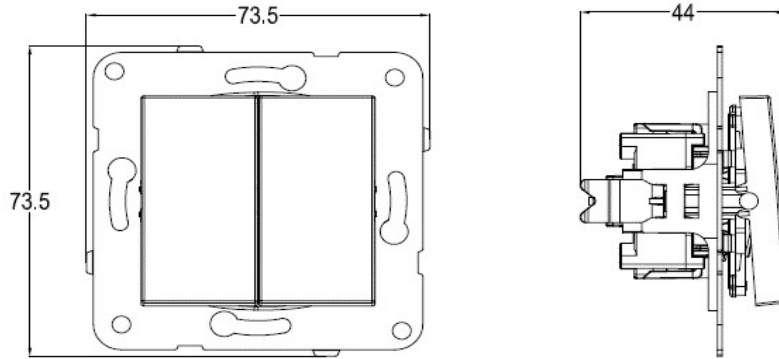

Panasonic Life Solutions Turkey Elektrik.San. ve Tic. A.Ş.
 Abdurrahmangazi Mah. Ebubekir Cad. No: 44 Sancaktepe / İstanbul Tel: 0216 564 55 55 Fax: 0216 564 55 44
 Istr.panasonic.com