

PRODUCT DATA SHEET

Panasonic

Product Name :	Two Gang Two Way Switch Mechanism+Button
Product Code :	PN.T01112 XX
Product Series :	Karre Plus
Technical Specifications :	
<i>Rated Current :</i>	10AX, 250V~
<i>Terminal Type :</i>	Quick Connection
<i>Material of Button :</i>	ABS (Acrylonitrile Butadine-Styrene)
Certifications :	VDE, EAC, CE, WEEE
Colour Options XX :	WH: White, DG: Dark Grey, SL: Silver, BL: Black
Cable Standard:	
<i>Cable Diameter :</i>	1mm ² -2,5mm ²
<i>Applicable Cable:</i>	Solid Wire, Stranded Wire

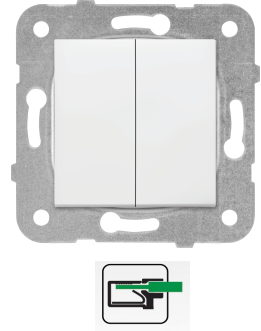

Wiring and Circuit Diagram :

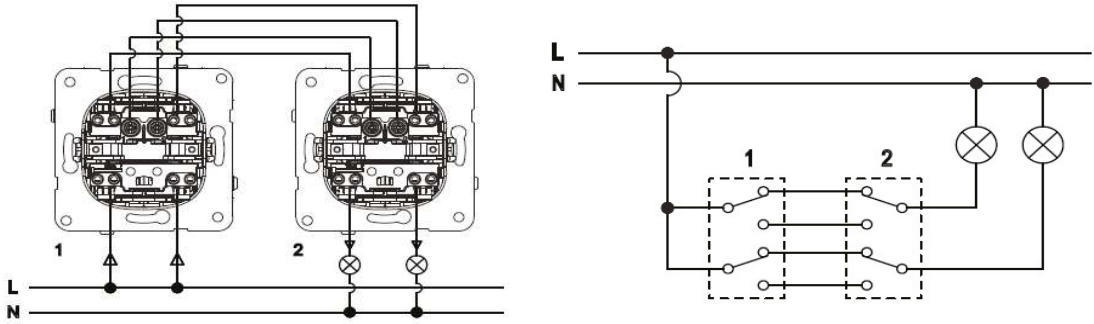

Dimensions :

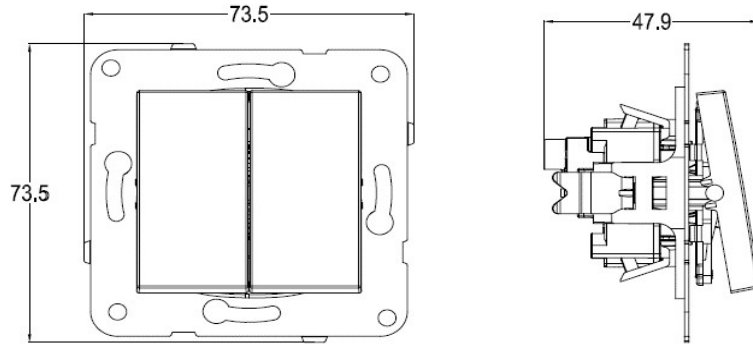

Panasonic Life Solutions Turkey Elektrik San. ve Tic. A.Ş.

Abdurrahmangazi Mah. Ebubekir Cad. No: 44 Sancaktepe / İstanbul Tel: 0216 564 55 55 Fax: 0216 564 55 44
Istr.panasonic.com